

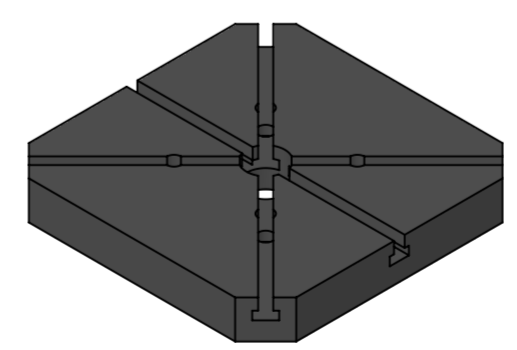

Optional mit T-Nut Tischplatte



Stempelgeschwindigkeit auf	50.9 mm/s	Dimension	1179x835x2023
Stempelgeschwindigkeit ab	36.7 mm/s	Gewicht	600 kg
Stueckzahl	1	Pos.	1
Gegenstand und Dimension		Werkstoff	585913.51
		Gew.p.St.	Zusammenst.-Nr.
		Gezeichnet	28.11.23
		Geprueft	
		Gesehen	
		Masstab	1:10
		 PRE.000.1308	
HP10N Hydraulikpresse 100 kN HEFTEC GmbH Automation & Engineering			