

Hydraulikaggregat

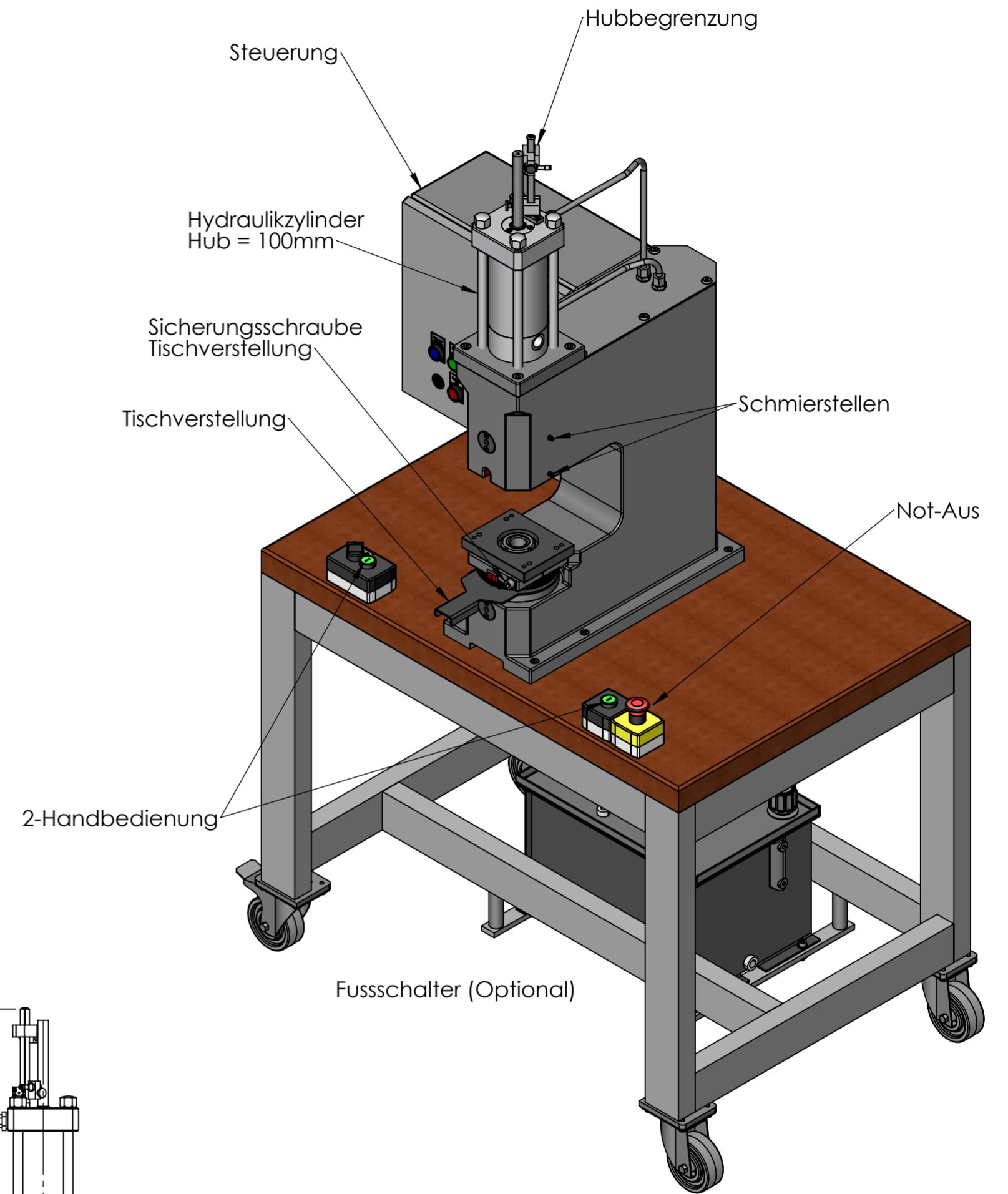
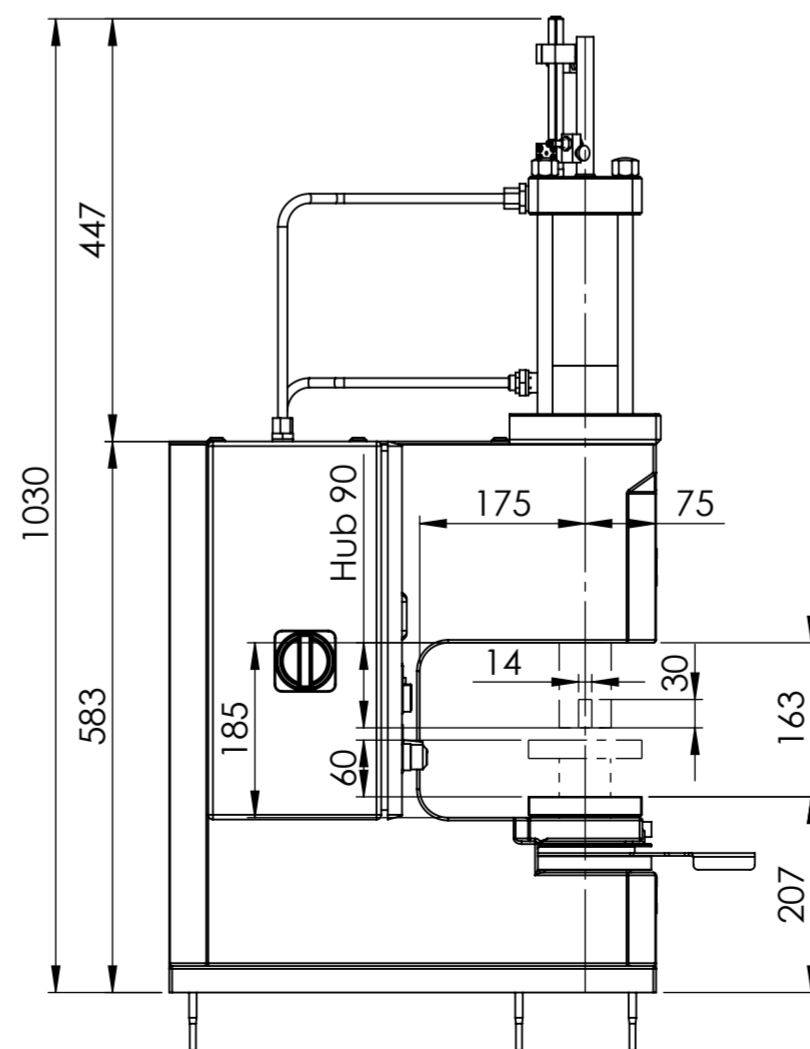
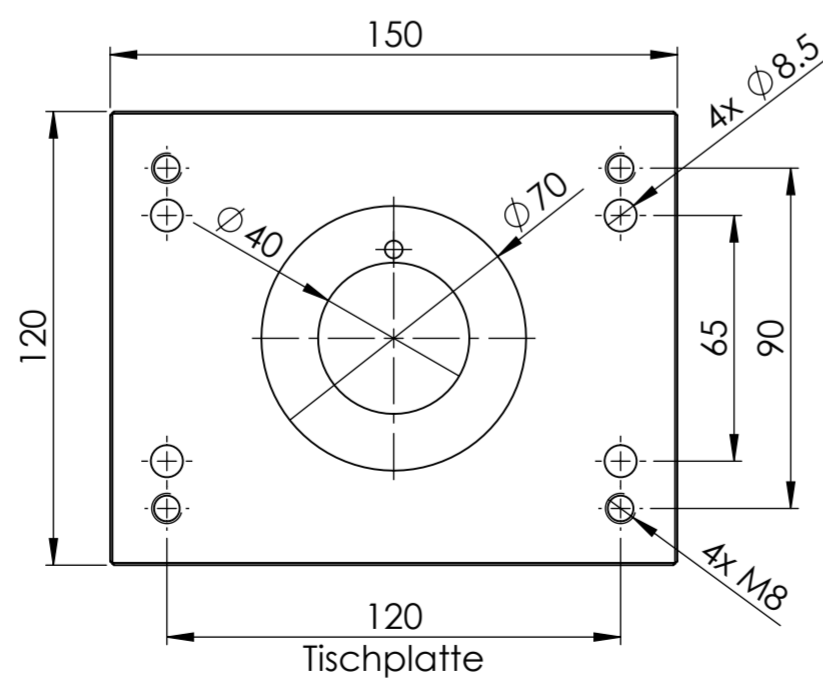
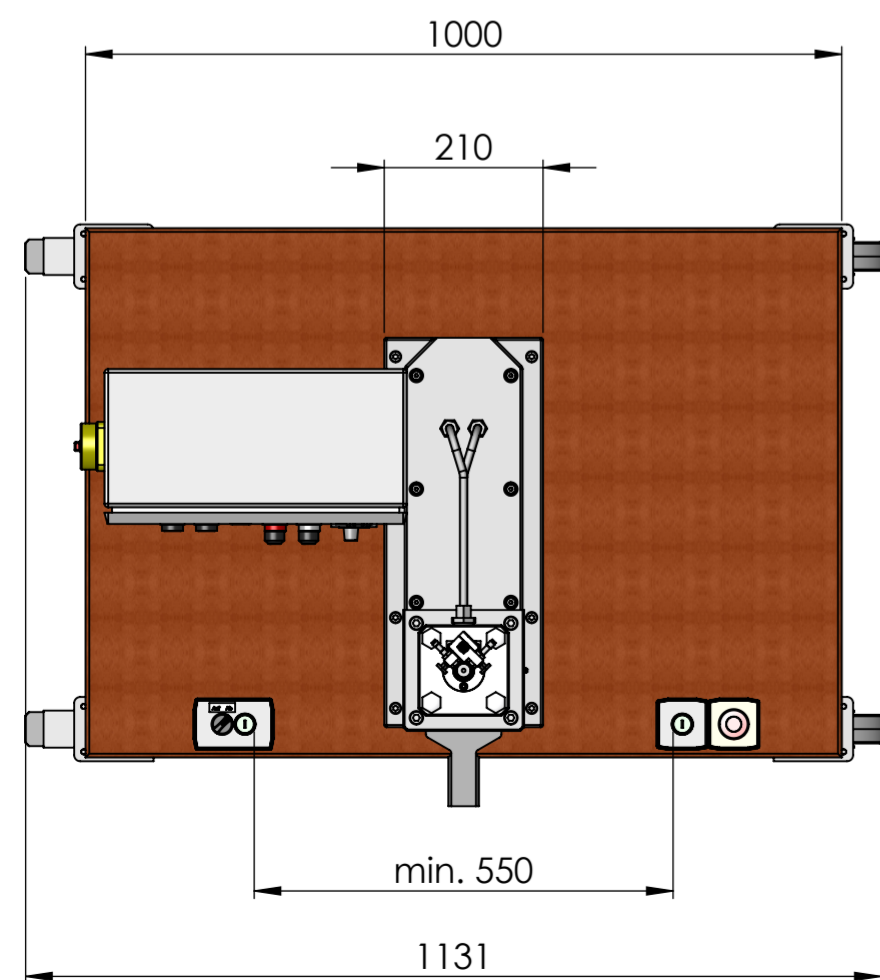
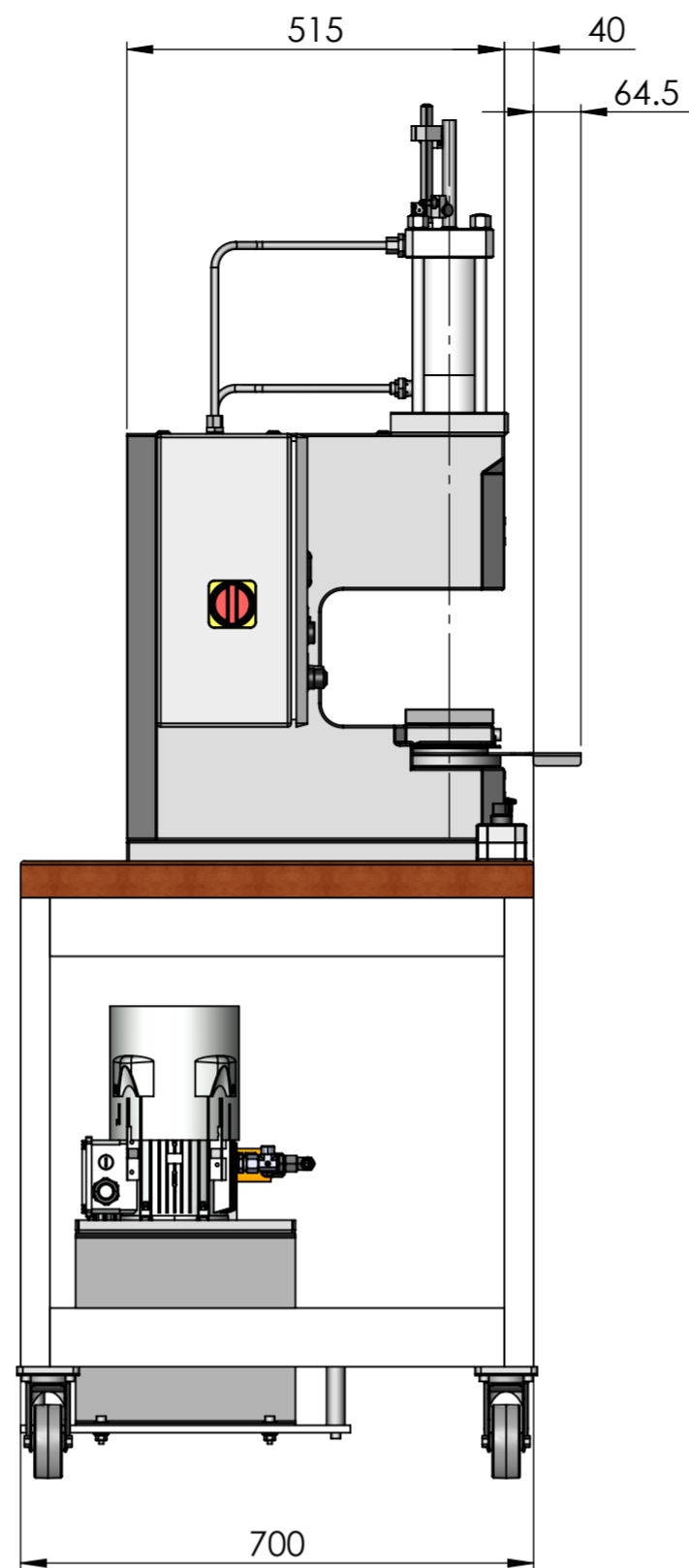

Stempelgeschwindigkeit auf	10 mm/s	Dimension	1131x700x1875
Stempelgeschwindigkeit ab	10 mm/s	Gewicht	620 kg
Stueckzahl	1	Pos.	1
Gegenstand und Dimension		Werkstoff	592464.39
		Gew.p.St.	Zusammenst.-Nr.
		Gezeichnet	28.11.23
		Geprueft	
		Gesehen	
<b>HP5W</b> Hydraulikpresse 70 kN HEFTEC GmbH Automation & Engineering		Massstab 1:10	PRE.000.1307