

Hydraulikaggregat

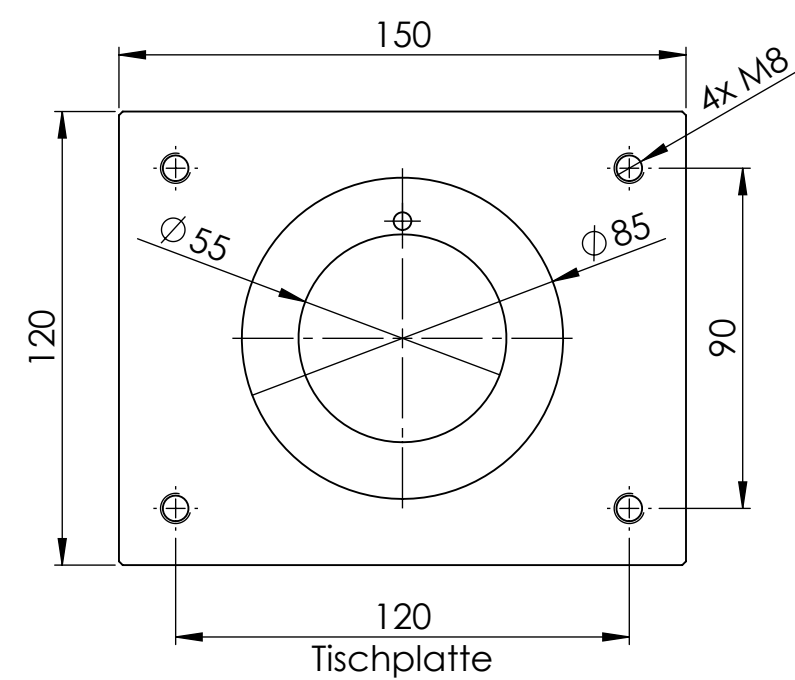

Tischplatte

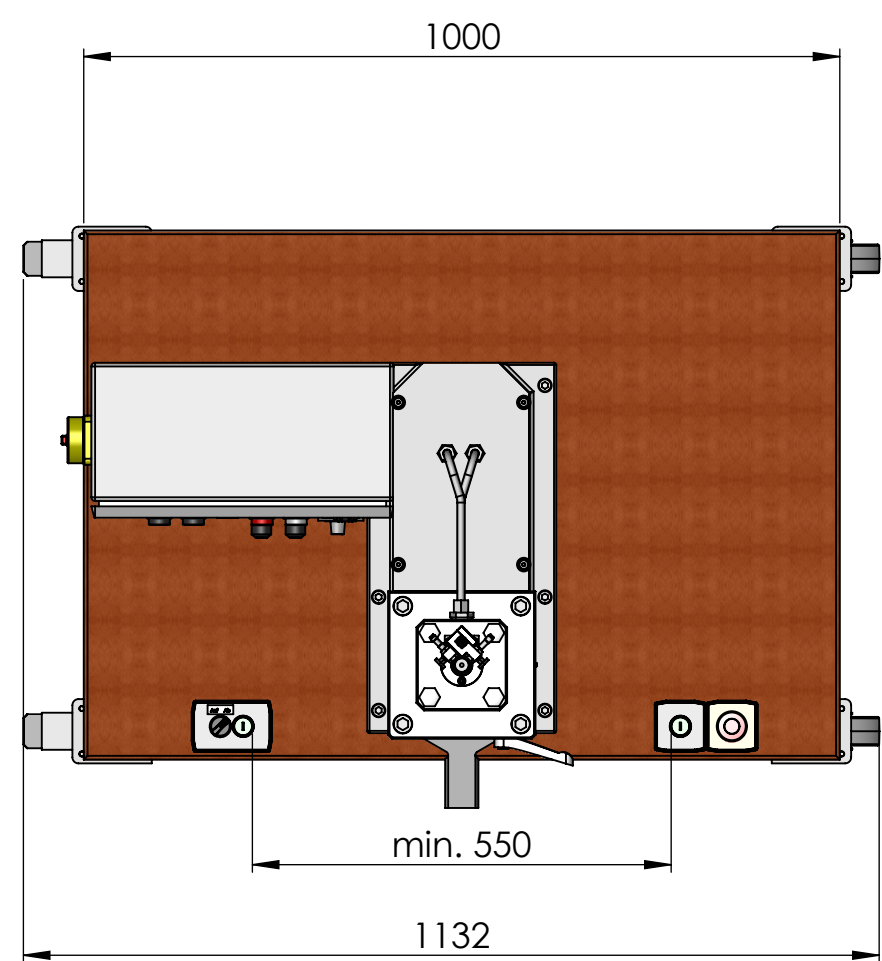
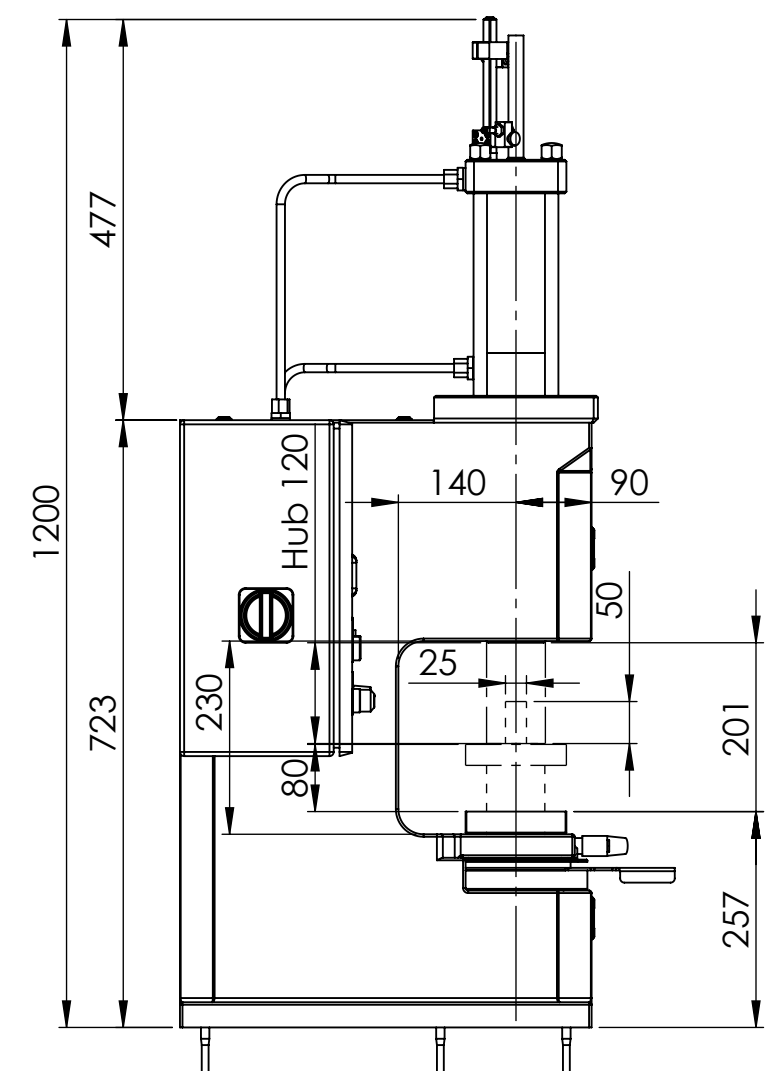
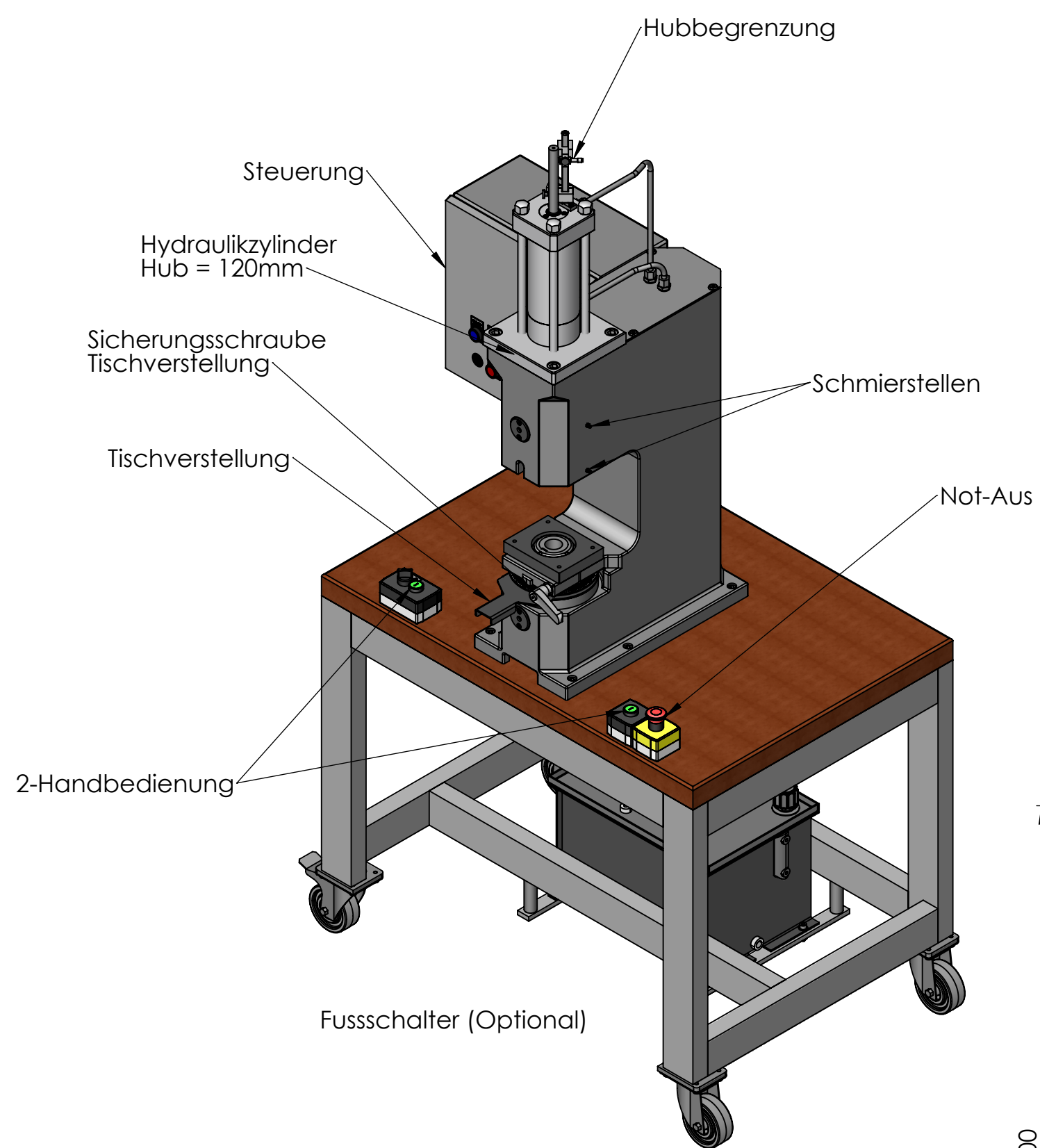
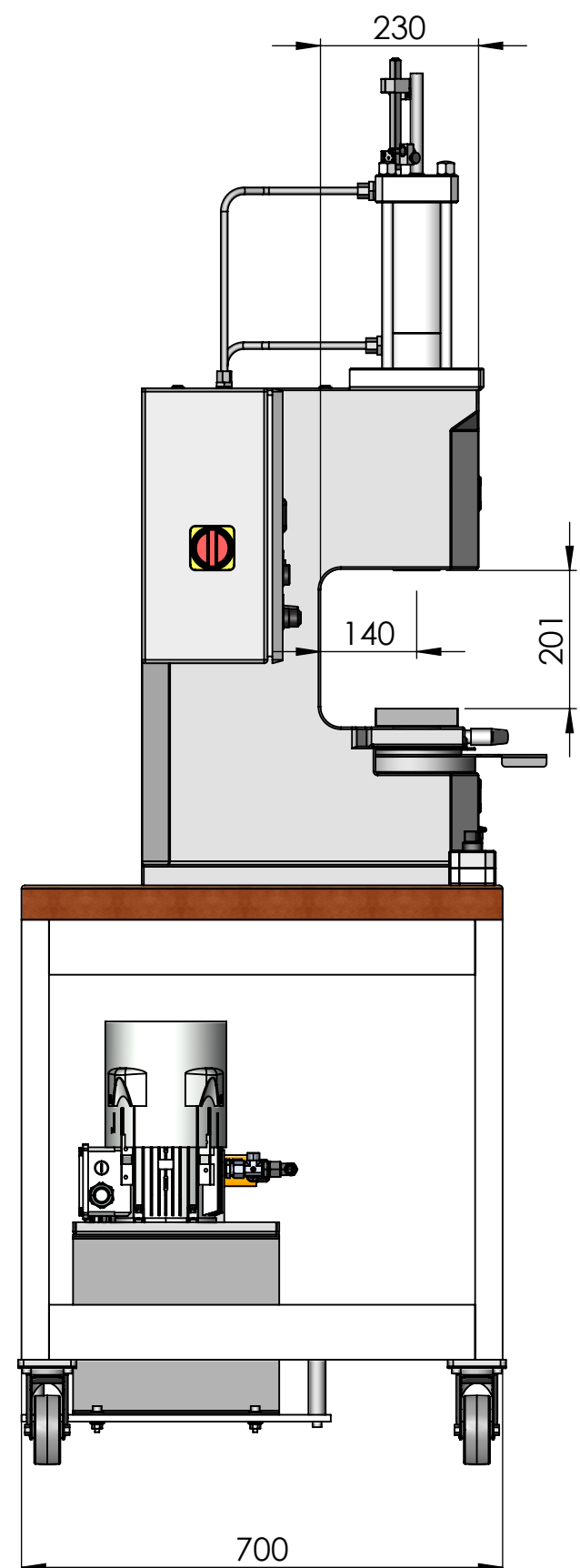
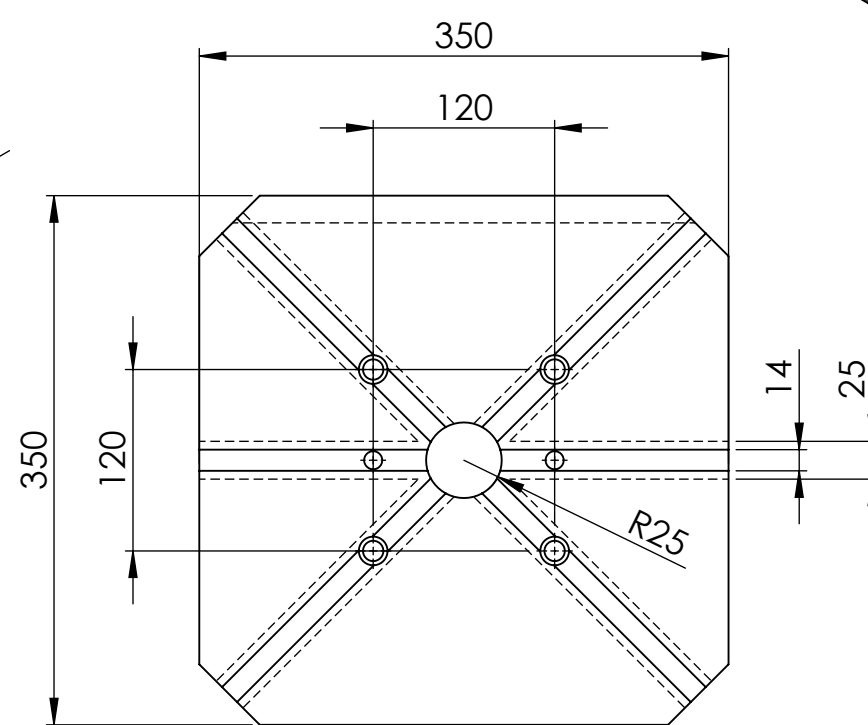

Optional mit T-Nut Tischplatte

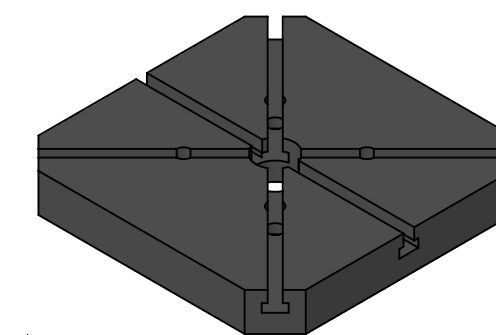

Stempelgeschwindigkeit auf	10 mm/s	Dimension	1132x700x2045		
Stempelgeschwindigkeit ab	10 mm/s	Gewicht	640 kg		
Stueckzahl	1	Pos.	1	622027.66	
Gegenstand und Dimension		Werkstoff		Zchng.-Nr. Norm-Nr.	Artikel-Nr. Bemerkungen
					Zusammenst.-Nr.
<b>HP10N</b> Hydraulikpresse 100 kN HEFTEC GmbH Automation & Engineering				Massstab 1:10	Gezeichnet 28.11.23 bd Geprüft Gesehen
				 <b>PRE.000.1302</b>	