

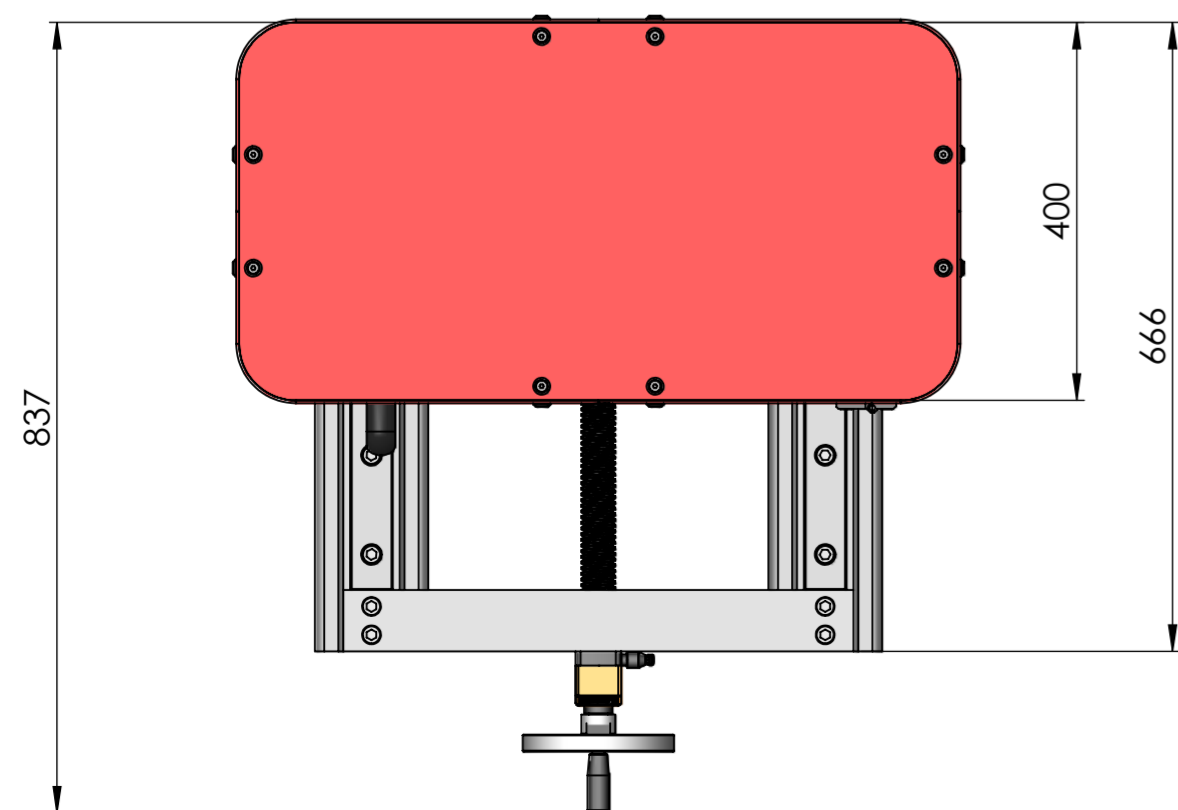

Hydraulikzylinder
Hub = 110mm

Schutztür mit Sicherheitsschalter

Tischverstellung

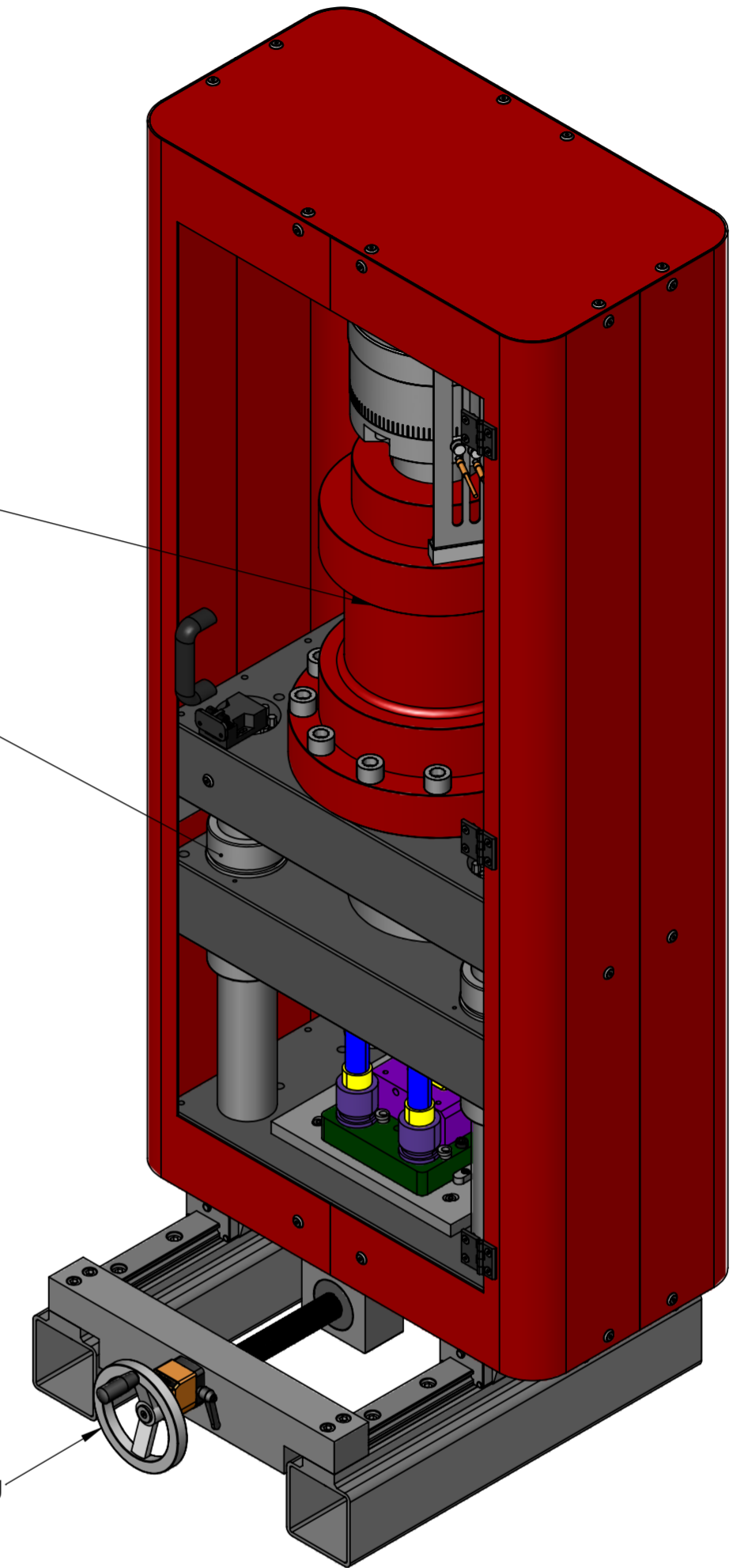

Stempelgeschwindigkeit auf	30.3 mm/s	Dimension	760x837x1901	
Stempelgeschwindigkeit ab	30.3 mm/s	Gewicht	1760 kg	
Stueckzahl	1	Pos.	1	1756235.43
	Gegenstand und Dimension		Werkstoff	Gew.p.St.
IV	III	II	I	
				Zusammenst.-Nr.
HP600-4S Hydraulikpresse 600 kN				Masstab 1:8
HEFTEC GmbH Automation & Engineering				Gezeichnet 10.11.16 PM Geprüft Gesehen
				 PRE.000.1141