

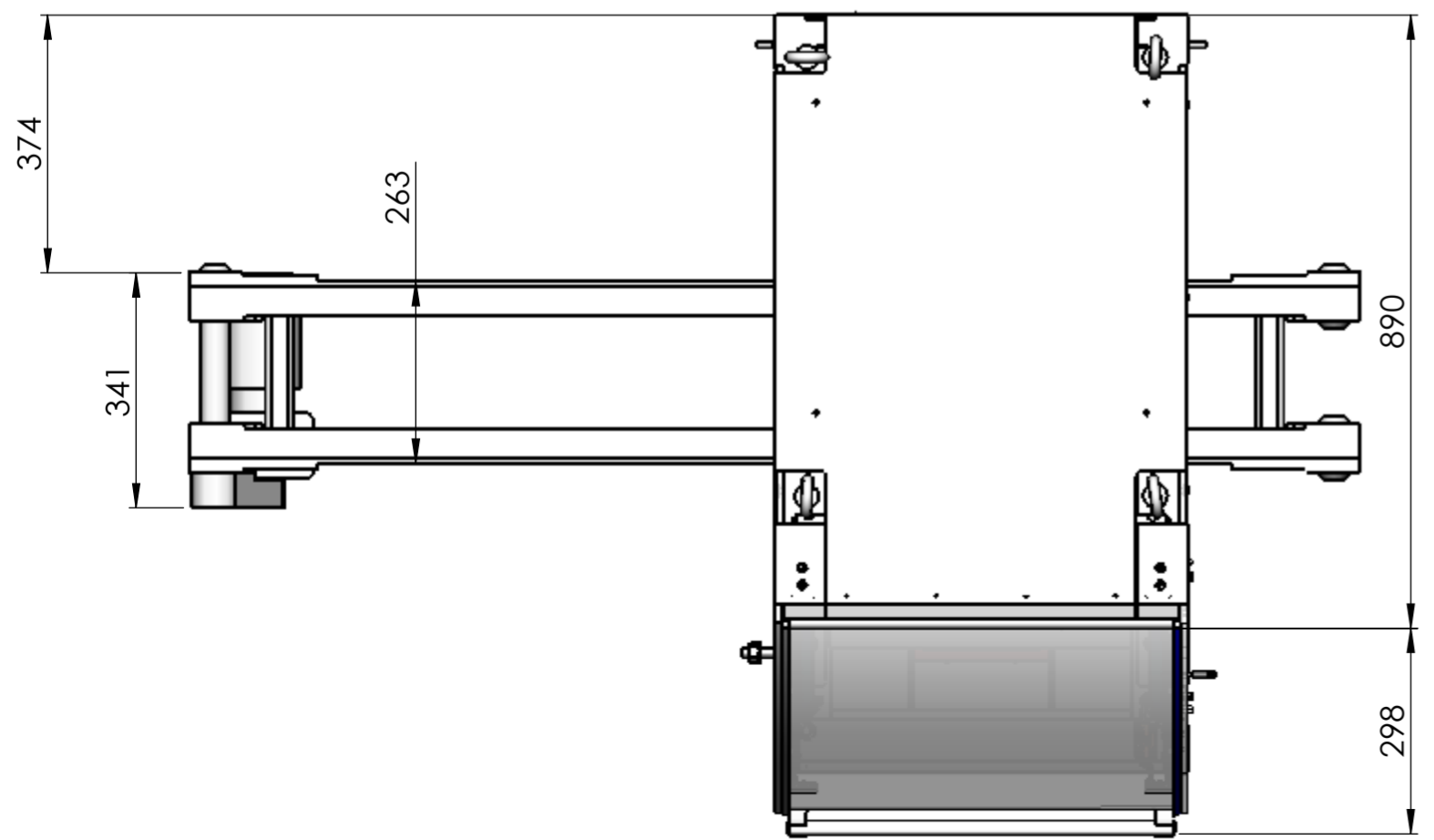

Pneumatikzylinder  
Hub = 200 mm



Stempelgeschwindigkeit auf	130 mm/s	Dimension	1156x1700x2197
Stempelgeschwindigkeit ab	90 mm/s	Gewicht	350 kg

1	1	349869.21			
Stueckzahl	Gegenstand und Dimension	Pos.	Werkstoff	Gew.p.St.	Zusammenst.-Nr.
IV	III	II	I		
<b>PP18-4S</b> Pneumatikpresse 18 kN				Massstab 1:10	Gezeichnet 09.11.16 nk Geprueft Gesehen
HEFTEC GmbH Automation & Engineering			 <b>PRE.000.1139</b>		