

Pneumatische Bremse
 Zylinder 80x5
 Bremsdrehmoment bei
 6 bar: 40 Nm
 Rotationsenergie bei
 voller Rolle mit 150kg
 d=1.2m
 31.25 J (Nm)
 Nachlaufen bei 60m/min
 ca. 750mm Vlies

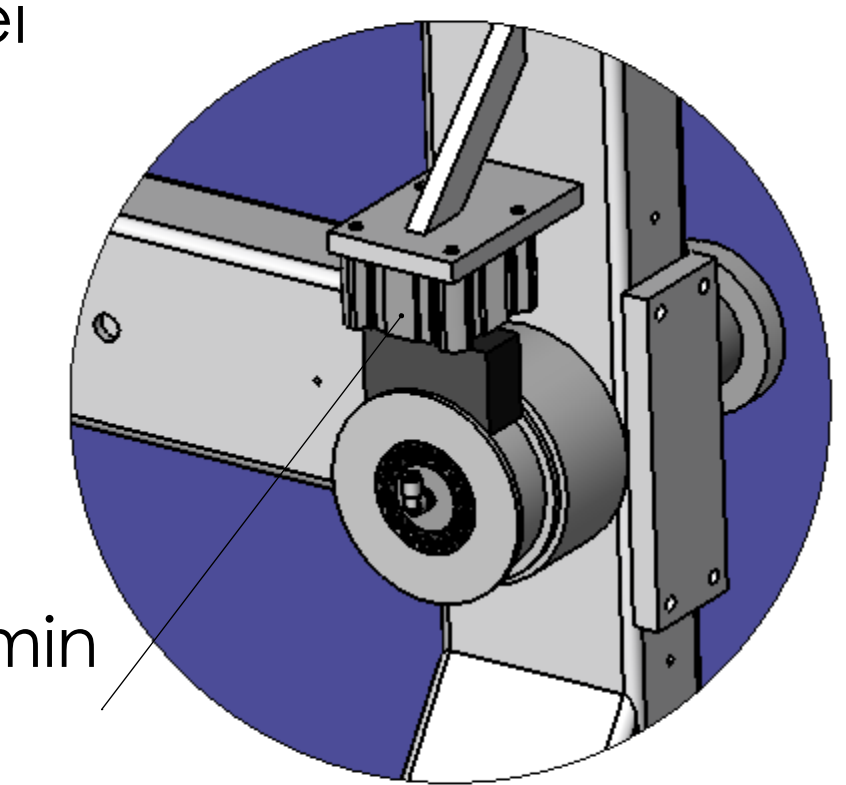

A (1:5)

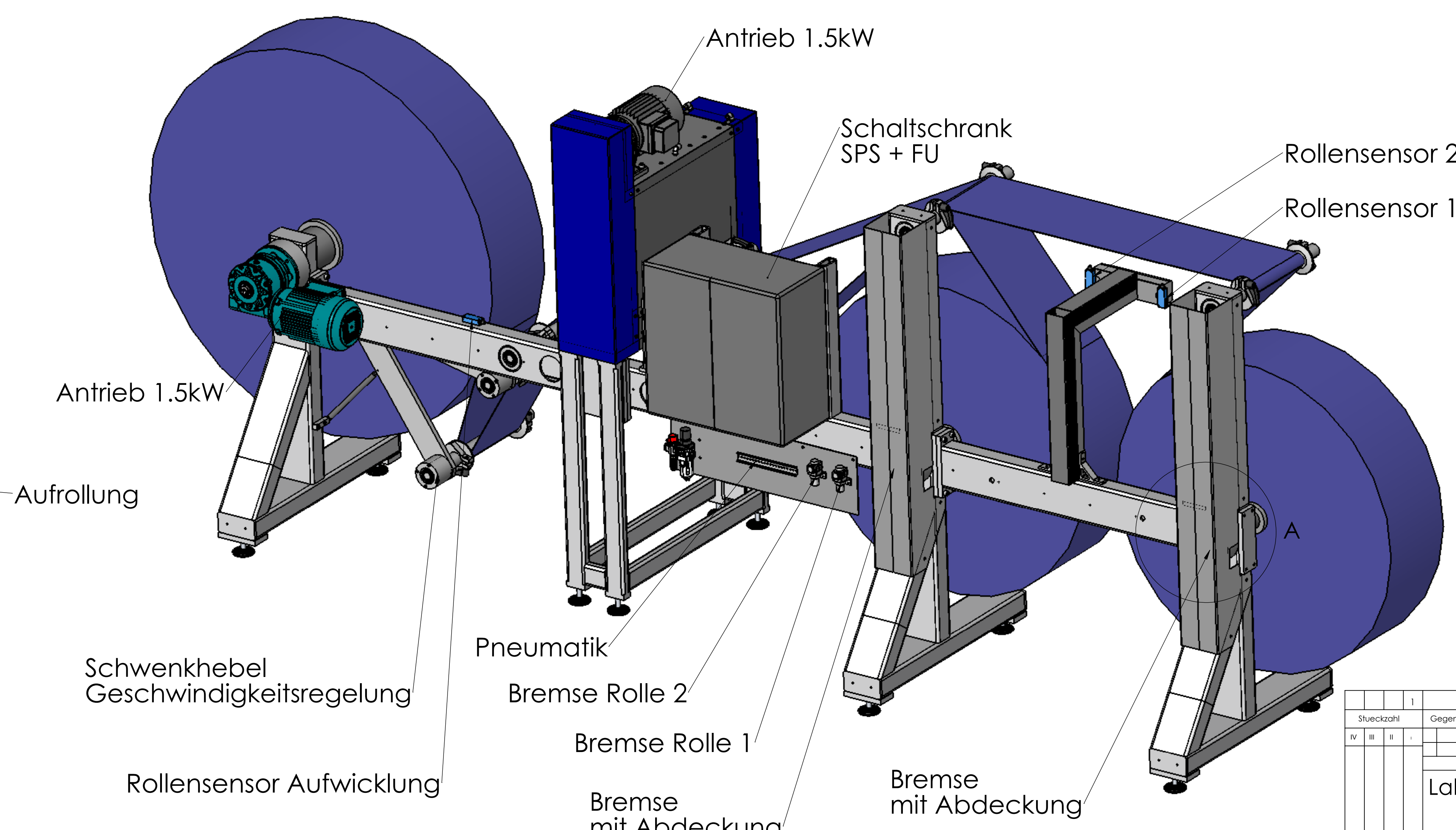
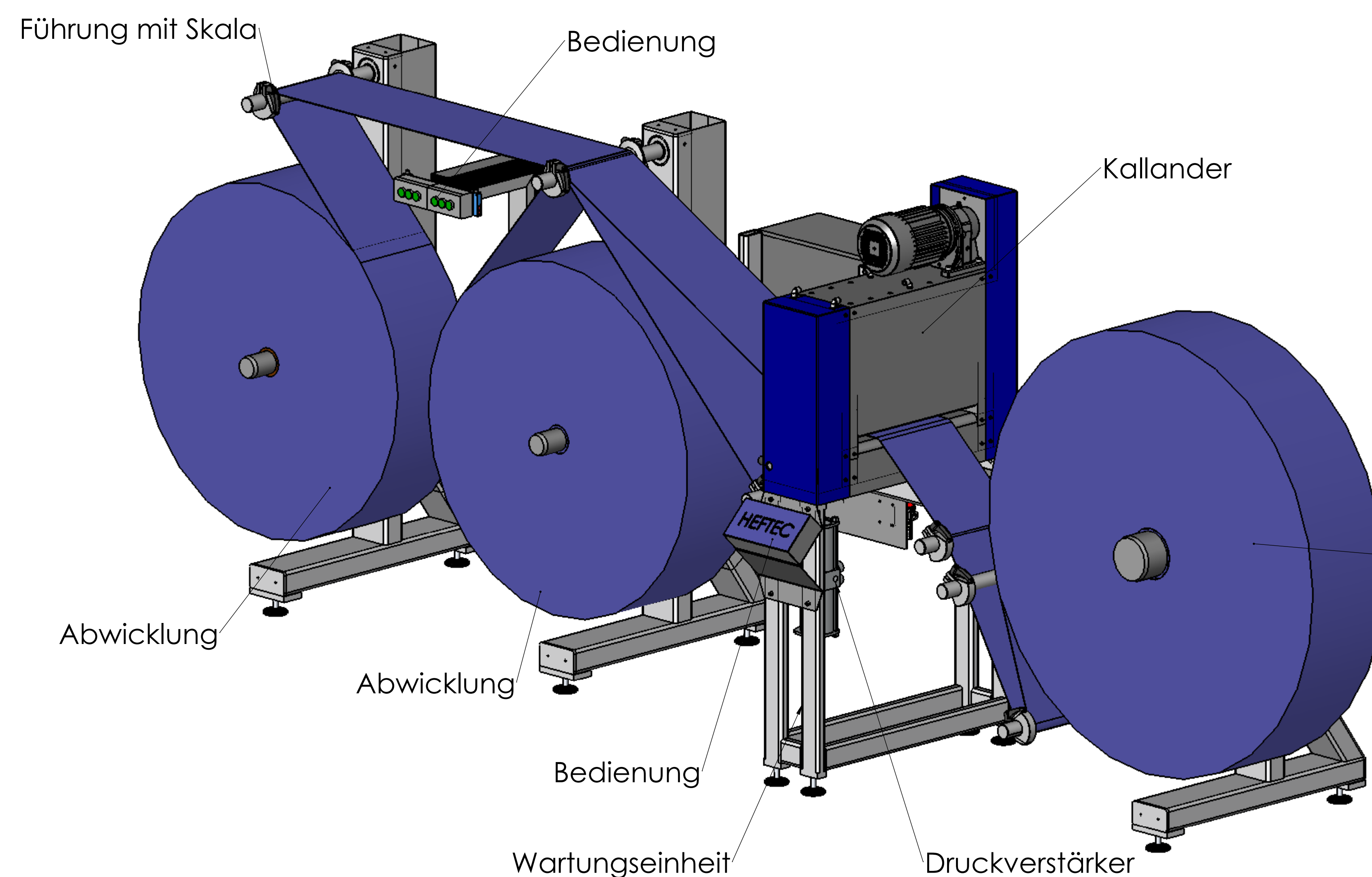

Verbraucher:
 1x Kallander 1.5kW
 1x Aufrollung 1.5kW
 2x Heizpatrone 1.8kW

Dimension	1371x5430x1878
Gewicht	1645 kg

Stückzahl	1	1645402.13	18.11.16	rik
IV	III	II	I	
Gegenstand und Dimension		Proc.	Werkstoff	Stück-Nr.
Laborkalender		Proz.	Werkstoff	Stück-Nr.
HEFTEC GmbH		Proz.	Werkstoff	Stück-Nr.
Automation & Engineering		Proz.	Werkstoff	Stück-Nr.
CPM.000.1252		Proz.	Werkstoff	Stück-Nr.